

Modular Type Common Supply Regulator

New

RoHS

Supply different pressure for multiple applications

OUT port is on the back of the product.

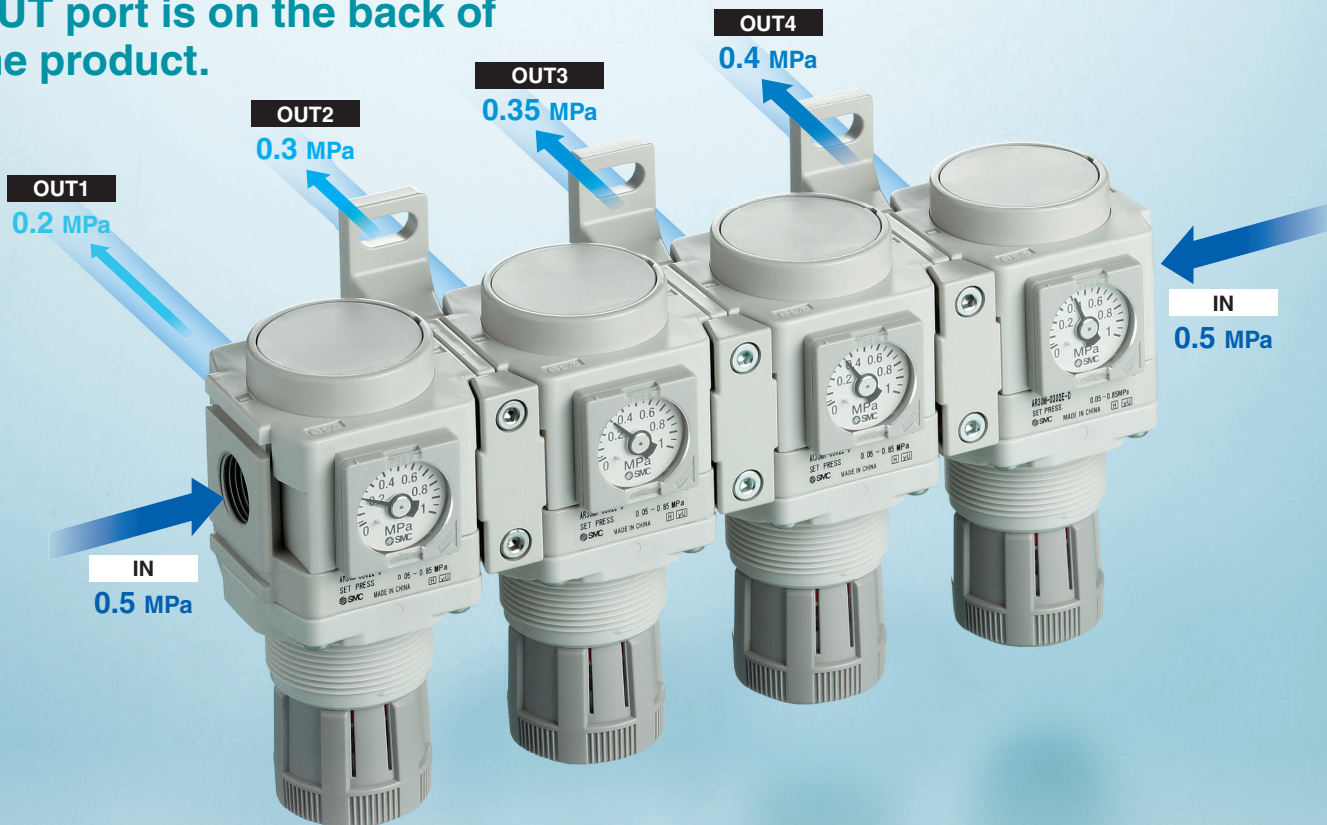

Space-saving design and reduced piping labour

* When using 30 size units assembled with \varnothing 10 fittings

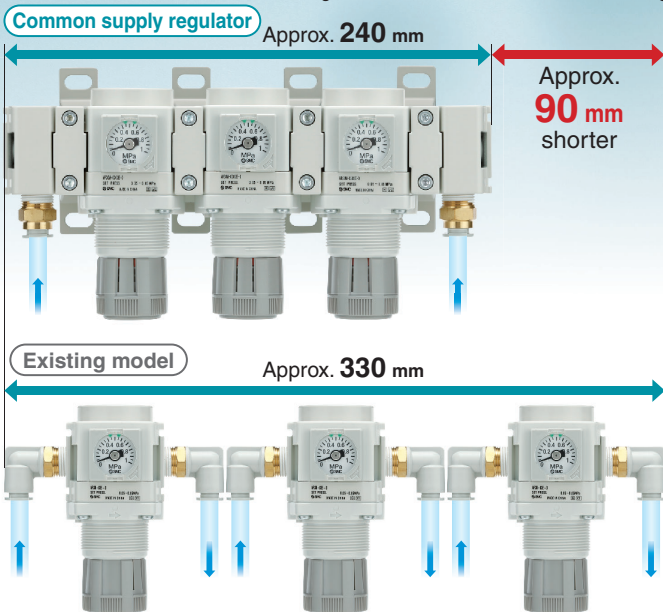

Modular connection is possible

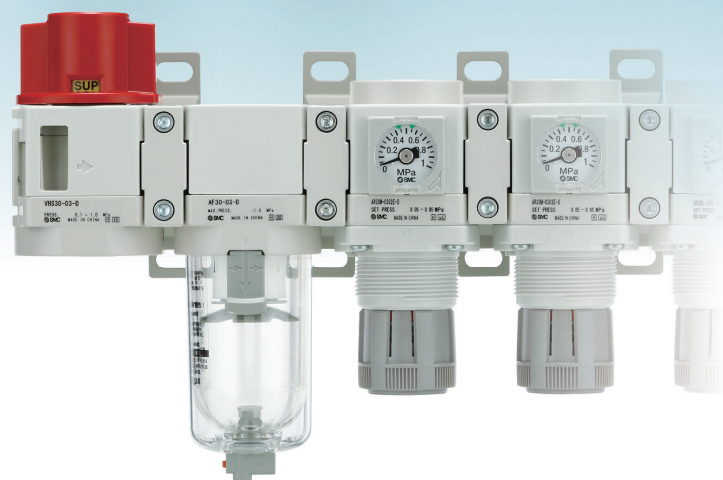

AR□M(K)-D Series



CAT.EUS40-72A-UK

Reduced piping labour and space-saving design

- Can be connected as a module with F.R.L. combination (AC-D series). One F.R.L. unit can then control pressure for multiple different air lines.
- Complicated tube arrangement and multiple fittings are no longer required.

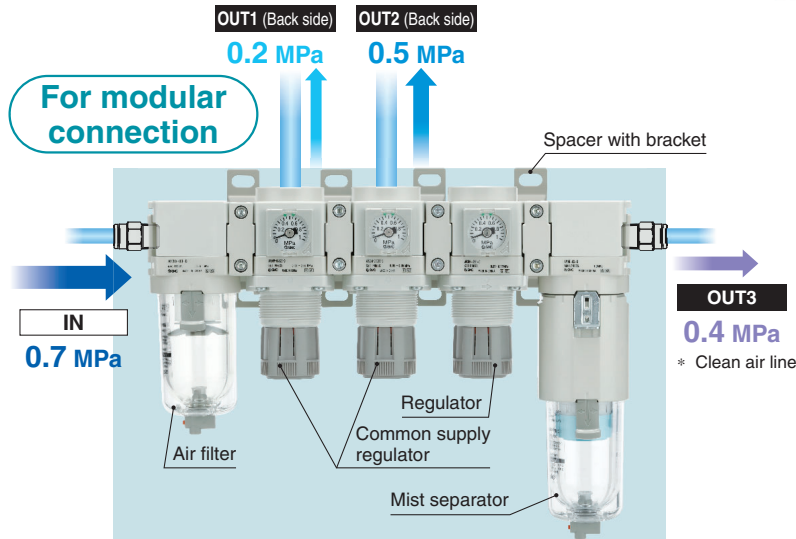
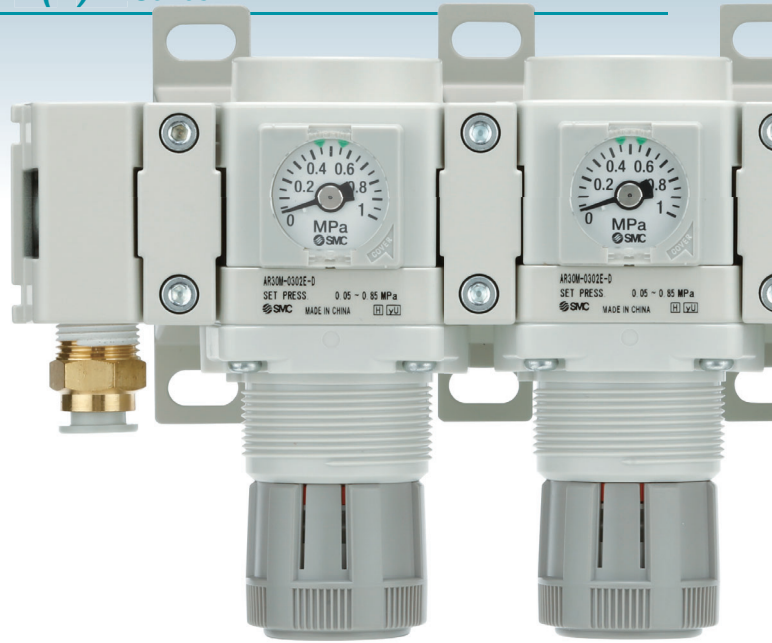

For tube piping

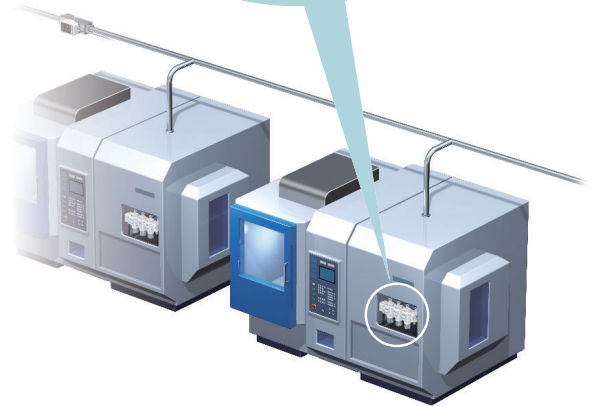
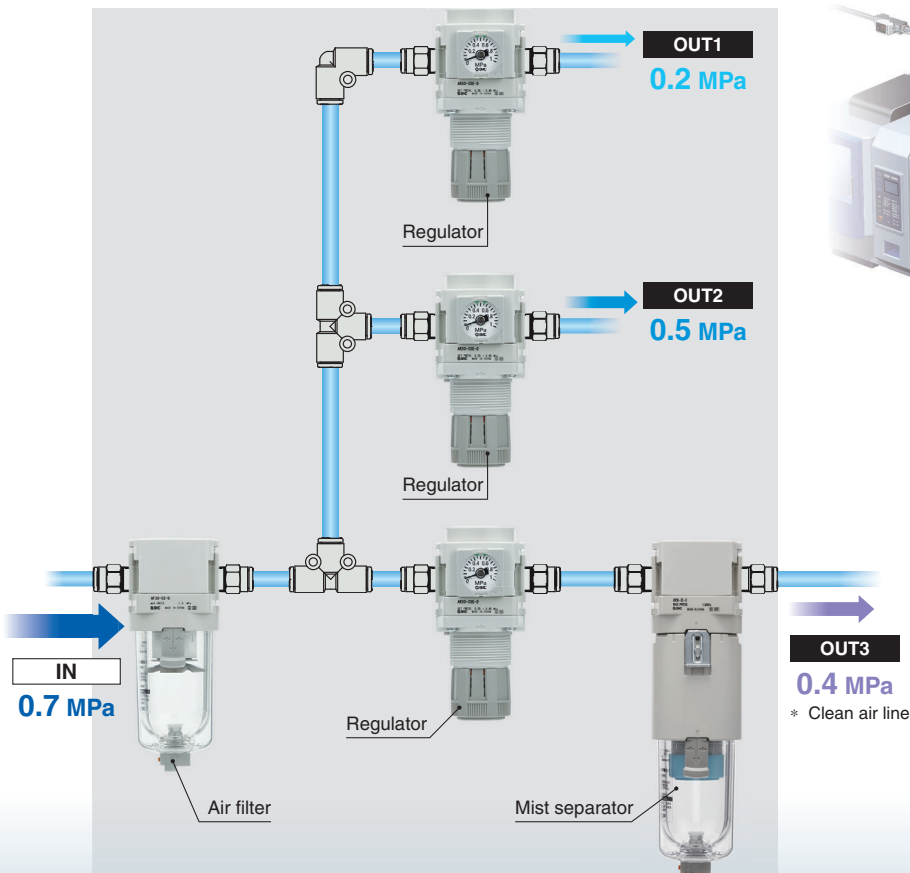

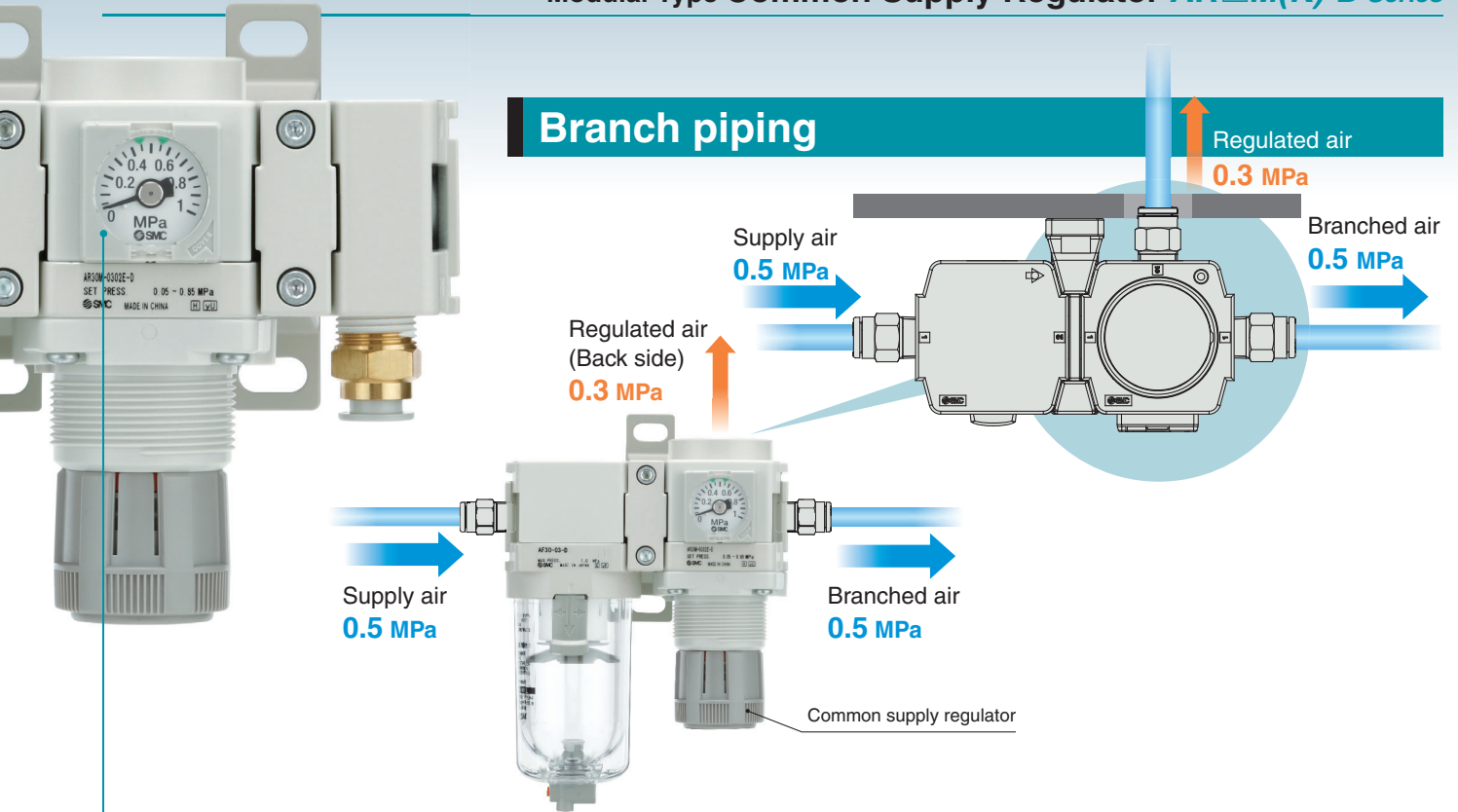

Selection of pressure gauges



Square embedded type pressure gauge



Round type pressure gauge



Digital pressure switch

Open/close type gauge cover

- 1 Open the gauge cover.
 - 2 Adjust the indicator to a specified position.
 - 3 Close the gauge cover.
-
- Open the gauge cover in the direction of the arrow with your fingertips.
- Adjust the indicator to a specified position using a flat blade screwdriver.
- Close the gauge cover in the direction of the arrow and push it in until it clicks in place.

Easy to handle

Easy to hold when unlocked

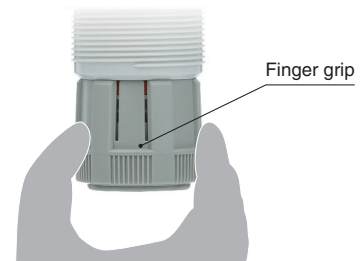

Locked

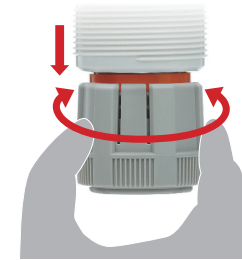

Pressure regulation while unlocked

Simple Specials System

For modular connection units (shipped assembled), the simple specials system can be used.

Modular Connection Examples

Refer to page 9.



Short lead times

This system enables us to respond to your special needs (accessory assembly or the designing of a modular unit) as quickly as standard products.

Repeat orders

Once we receive a simple special part number from one of your previous orders, we will process the order, manufacture the product, and deliver it to you as quickly as possible.

Please contact your local sales representative for more details.

Common Supply Regulator

AR20M-D to AR40M-D

Common Supply Regulator with Backflow Function

AR20MK-D to AR40MK-D

Symbol

Common Supply Regulator

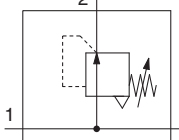

Common Supply Regulator with Backflow Function

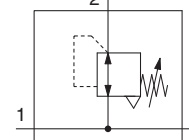

- Models with the backflow function include a mechanism which allows for the air pressure in the outlet side to be released to the inlet side.

When the air supply is cut off and releasing the inlet pressure to the atmosphere, the residual pressure release of the outlet side can be ensured for a safety purpose.

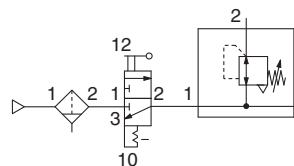

How to Order

AR **30** **M** **K** - **F** **03** **02** **BE** - - D

1
 2
 3
 4
 5
 6
 7

• Common supply type

- Option/Semi-standard: Select one each for a to f.
- Option/Semi-standard symbol: When more than one specification is required, indicate in alphanumeric order.

	Symbol	Description	① Body size				
			20	30	40		
② With backflow function	—	Without backflow function	●	●	●		
	K	With backflow function*1	●	●	●		
③ Pipe thread type	—	Rc	●	●	●		
	N	NPT	●	●	●		
	F	G	●	●	●		
④ IN port size	01	1/8	●	—	—		
	02	1/4	●	●	—		
	03	3/8	—	●	●		
	04	1/2	—	—	●		
⑤ OUT port size	01	1/8	●	—	—		
	02	1/4	●*2	●	●		
	03	3/8	—	—	●		
⑥ Option*3	a Mounting	—	Without mounting option	●	●	●	
		B*4	With bracket	●	●	●	
		H	With set nut (for panel mount)	●	●	●	
	b Pressure gauge*5	—	Without pressure gauge	●	●	●	
		E	Square embedded type pressure gauge (with limit indicator)	●	●	●	
		G	Round type pressure gauge (with limit indicator)	●	●	●	
		M	Round type pressure gauge (with colour zone)	●	●	●	
		Digital pressure switch*6	E1	Output: NPN output, Electrical entry: Wiring bottom entry	●	●	●
			E2	Output: NPN output, Electrical entry: Wiring top entry	●	●	●
			E3	Output: PNP output, Electrical entry: Wiring bottom entry	●	●	●
E4	Output: PNP output, Electrical entry: Wiring top entry		●	●	●		
⑦ Semi-standard	c Set pressure*7, *8	—	0.05 to 0.85 MPa setting	●	●	●	
		1	0.02 to 0.2 MPa setting	●	●	●	
	d Exhaust mechanism	—	Relieving type	●	●	●	
N		Non-relieving type	●	●	●		

Common Supply Regulator **AR20M-D to AR40M-D Series**

Common Supply Regulator with Backflow Function **AR20MK-D to AR40MK-D Series**

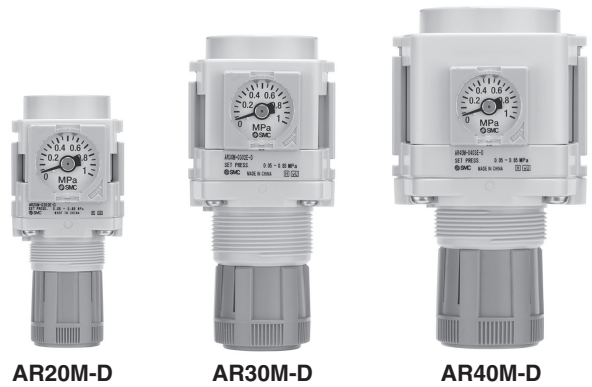

		Symbol	Description	①				
				Body size				
				20	30	40		
⑦	Semi-standard	e	Knob	—	Downward	●	●	●
				Y	Upward	●	●	●
	+							
	f	Pressure unit	—	Name plate and pressure gauge in SI units: MPa	●	●	●	
			Z*9	Name plate, caution plate, and pressure gauge in imperial units: psi/°F Digital pressure switch: With unit selection function (Initial unit: psi)	○*11	○*11	○*11	
			ZA*10	Digital pressure switch: With unit selection function (Initial unit: MPa)	△*12	△*12	△*12	

- *1 Set the inlet pressure to at least 0.05 MPa higher than the set pressure.
- *2 Selectable when the port size of the IN side is 1/4.
- *3 Options B, G, H, and M are not assembled and supplied loose at the time of shipment.
- *4 The assembly consists of a bracket and set nuts.
- *5 When the pressure gauge is attached, a 1.0 MPa pressure gauge will be fitted for standard (0.85 MPa) type. 0.4 MPa pressure gauge for 0.2 MPa type.
- *6 When choosing with H (panel mount), the installation space for lead wires will not be secured. In this case, select "wiring bottom entry" for the electrical entry. (Select "wiring bottom entry" when the semi-standard Y is chosen simultaneously.)
- *7 Pressure can be set higher than the specification pressure in some cases, but use pressure within the specification range.
- *8 For models with a backflow function, the minimum set pressure is 0.1 MPa.
- *9 For the pipe thread type: NPT
This product is for overseas use only according to the New Measurement Act. (The SI unit type is provided for use in Japan.) Cannot be used with M: Round type pressure gauge (with colour zone). Available by request for special. The digital pressure switch will be equipped with the unit selection function, setting to psi initially.
- *10 For options: E1, E2, E3, E4
- *11 ○: For the pipe thread type: NPT only
- *12 △: Select with options: E1, E2, E3, E4.

AR20M-D to AR40M-D Series

AR20MK-D to AR40MK-D Series

Standard Specifications

Model		AR20M(K)-D		AR30M(K)-D		AR40M(K)-D	
		IN side	OUT side	IN side	OUT side	IN side	OUT side
Port size		1/8	1/8	—	—	—	—
		1/4	1/8	1/4	1/4	—	—
			1/4				
		—	—	3/8	1/4	3/8	1/4
		—	—	—	—	1/2	1/4
						3/8	
Pressure gauge port size*1		1/8					
Fluid		Air					
Ambient and fluid temperatures*2		-5 to 60 °C (No freezing)					
Proof pressure		1.5 MPa					
Max. operating pressure		1.0 MPa					
Set pressure range	Without backflow function	0.05 to 0.85 MPa					
	With backflow function	0.1 to 0.85 MPa					
Construction		Relieving type					
Weight		0.16 kg		0.29 kg		0.50 kg	

*1 Pressure gauge connection threads are not available for F.R.L. unit with a square embedded type pressure gauge or with a digital pressure switch.

*2 -5 to 50 °C for the products with the digital pressure switch

Option/Part Nos.

Optional specifications			Model		
			AR20M(K)-D	AR30M(K)-D	AR40M(K)-D
Bracket assembly*1			AR23P-270AS	AR33P-270AS	AR43P-270AS
Set nut			AR23P-260S	AR33P-260S	AR43P-260S
Pressure gauge*2	Round type	Standard	G36-10-□01		G46-10-□01
		0.02 to 0.2 MPa setting	G36-4-□01		G46-4-□01
	Round type (with colour zone)	Standard	G36-10-□01-L		G46-10-□01-L
		0.02 to 0.2 MPa setting	G36-4-□01-L		G46-4-□01-L
	Square embedded type*3	Standard	GC3-10AS-D [136150A (Pressure gauge cover only)]		
0.02 to 0.2 MPa setting		GC3-4AS-D [136150A (Pressure gauge cover only)]			
Digital pressure switch	NPN output, Wiring bottom entry		ISE35-N-25-MLA-X523 [ISE35-N-25-M (Switch body only)]*4		
	NPN output, Wiring top entry		ISE35-R-25-MLA-X523 [ISE35-R-25-M (Switch body only)]*4		
	PNP output, Wiring bottom entry		ISE35-N-65-MLA-X523 [ISE35-N-65-M (Switch body only)]*4		
	PNP output, Wiring top entry		ISE35-R-65-MLA-X523 [ISE35-R-65-M (Switch body only)]*4		

*1 The assembly consists of a bracket and set nuts.

*2 □ in part numbers for a round pressure gauge indicates a pipe thread type. No indication is necessary for R; however, indicate N for NPT. Please contact SMC regarding the pressure gauge supply for psi unit specifications.

*3 Including one O-ring and 2 mounting screws. []: Pressure gauge cover only

*4 In addition to the pressure switch body, lead wire with connector (2 m), adapter, lock pin, O-ring (1 pc.), and mounting screws (2 pcs.) are attached. []: Switch body only (Regarding how to order the digital pressure switch, refer to the **Web Catalogue**.)

Replacement Parts

Description		Part no.		
		AR20M(K)-D	AR30M(K)-D	AR40M(K)-D
Valve assembly	Without backflow function	AR24P-060AS	AR34P-060AS	AR44P-060AS
	With backflow function	AR24KP-560AS	AR34KP-560AS	AR44KP-560AS
Diaphragm assembly	Relieving type	AR24P-150AS	AR34P-150AS	AR44P-150AS
	Non-relieving type	AR24P-150AS-N	AR34P-150AS-N	AR44P-150AS-N
Valve guide assembly		AR24P-050AS	AR34P-050AS	AR44P-050AS

Flow Rate Characteristics *1 (Representative values)

— Inlet pressure: 1.0 MPa
 - - - Inlet pressure: 0.7 MPa

AR20M(K)-D

IN: Rc1/4, OUT: Rc1/4

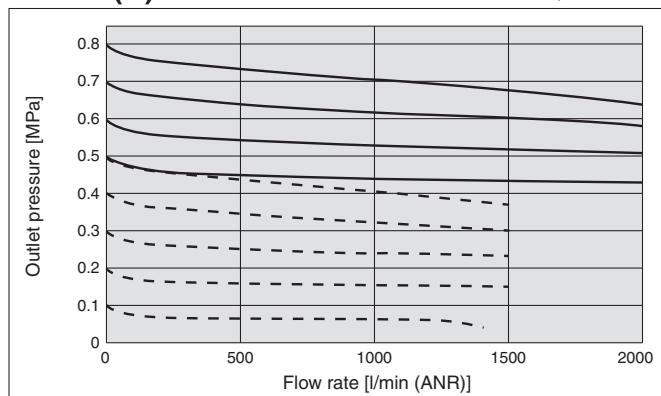

AR30M(K)-D

IN: Rc3/8, OUT: Rc1/4

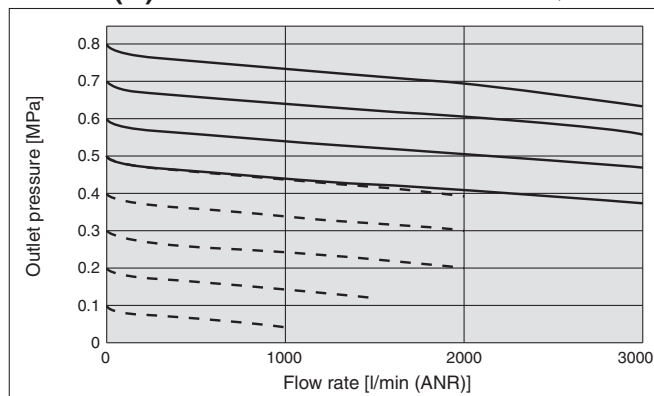

AR40M(K)-D

IN: Rc1/2, OUT: Rc3/8

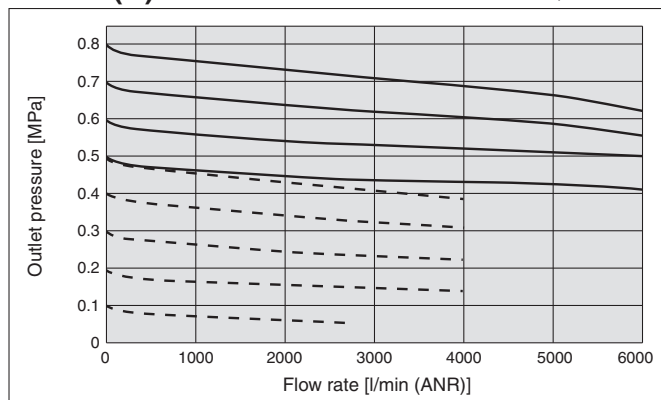

*1 This is the flow rate characteristics of the individual unit.

Pressure Characteristics (Representative values)

Conditions: Inlet pressure 0.7 MPa, Outlet pressure 0.2 MPa, Flow rate 20 L/min (ANR)

AR20M(K)-D

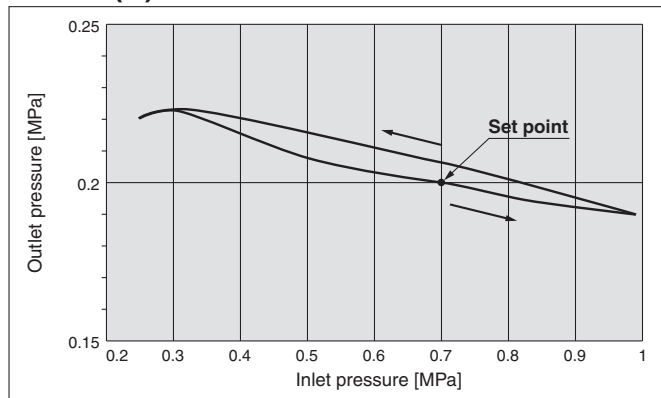

AR30M(K)-D

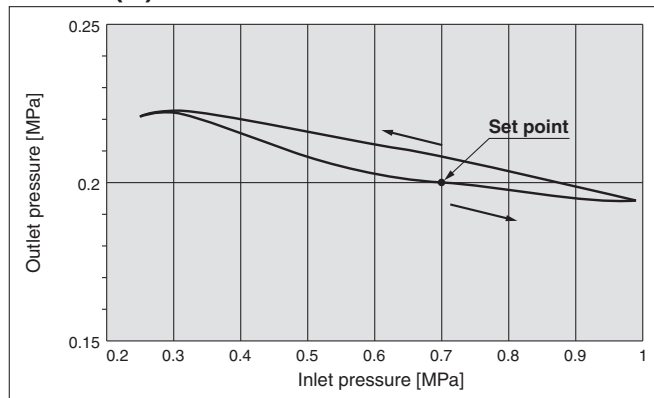

AR40M(K)-D

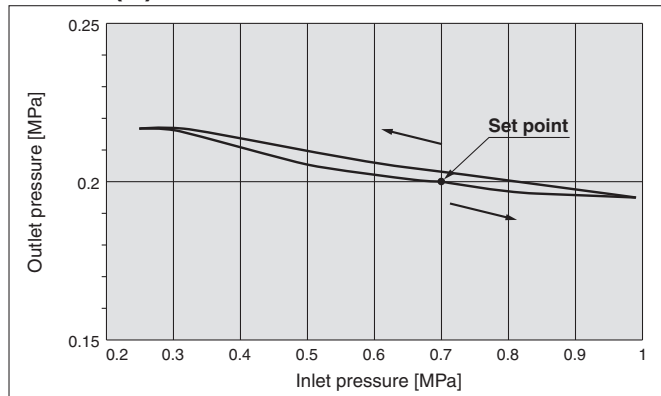

AR20M-D to AR40M-D Series

AR20MK-D to AR40MK-D Series

Dimensions

AR20M(K)-D to AR40M(K)-D

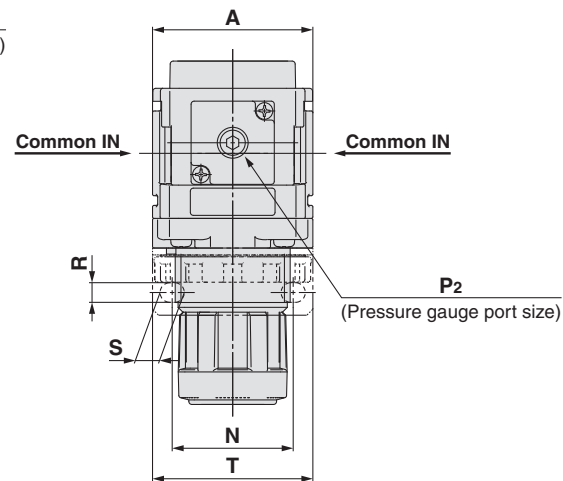
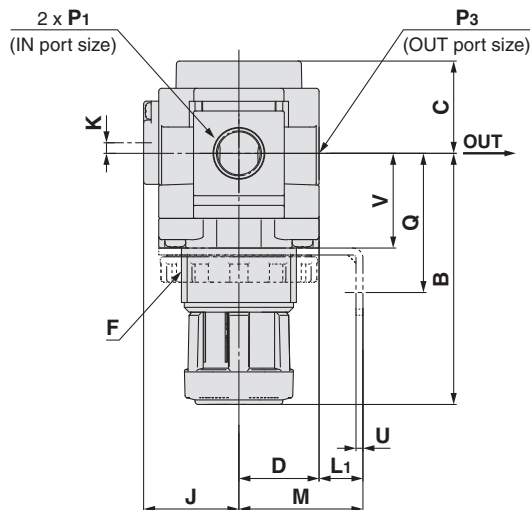
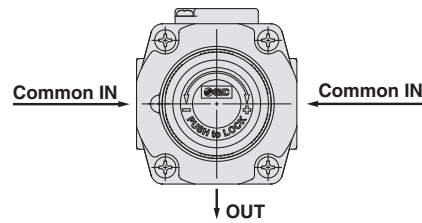
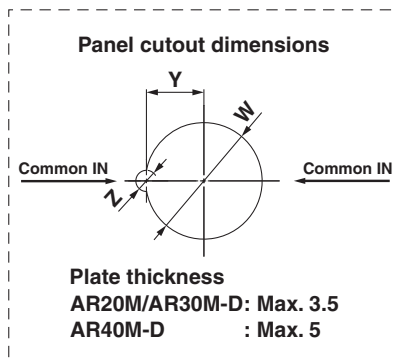

Round type pressure gauge	Square embedded type pressure gauge	Digital pressure switch

Model	Standard specifications											Optional specifications					
	P ₁	P ₂	P ₃	A	B* ¹	C	D	F	J	K	L ₁	H	J	H	J	H	J
AR20M(K)-D	1/8, 1/4	1/8	1/8, 1/4	40	66.8	26.5	21	M28 x 1	26	2	9	∅ 37.5	62.5	∅ 37.5	63.5	∅ 37.5	63.5
AR30M(K)-D	1/4, 3/8	1/8	1/4	53	86.5	30.5	26.5	M38 x 1.5	31.5	3.5	14.5	∅ 37.5	68	∅ 37.5	69	∅ 37.5	69
AR40M(K)-D	3/8, 1/2	1/8	1/4, 3/8	70	91.5	35.5	35.5	M42 x 1.5	40.5	0	14.5	∅ 42.5	78	∅ 42.5	78	∅ 42.5	78

Model	Optional specifications														
	Square embedded type pressure gauge		Digital pressure switch		Bracket mount						Panel mount* ²				
	H	J	H	J	M	N	Q	R	S	T	U	V	W	Y	Z
AR20M(K)-D	∅28	27	∅27.8	37.5	30	34	43.9	5.4	15.4	55	2.3	24.7	28.5	14	6
AR30M(K)-D	∅28	32.5	∅27.8	43	41	40	46	6.5	8	53	2.3	31.3	38.5	19	7
AR40M(K)-D	∅28	41.5	∅27.8	52	50	54	54	8.5	10.5	70	2.3	35.5	42.5	21	7

*1 The dimension of B is the length when the regulator knob is unlocked.

*2 Panel cutout dimensions in the table indicate the dimensions for panel mounting a single regulator.

Dimensions (When connected)

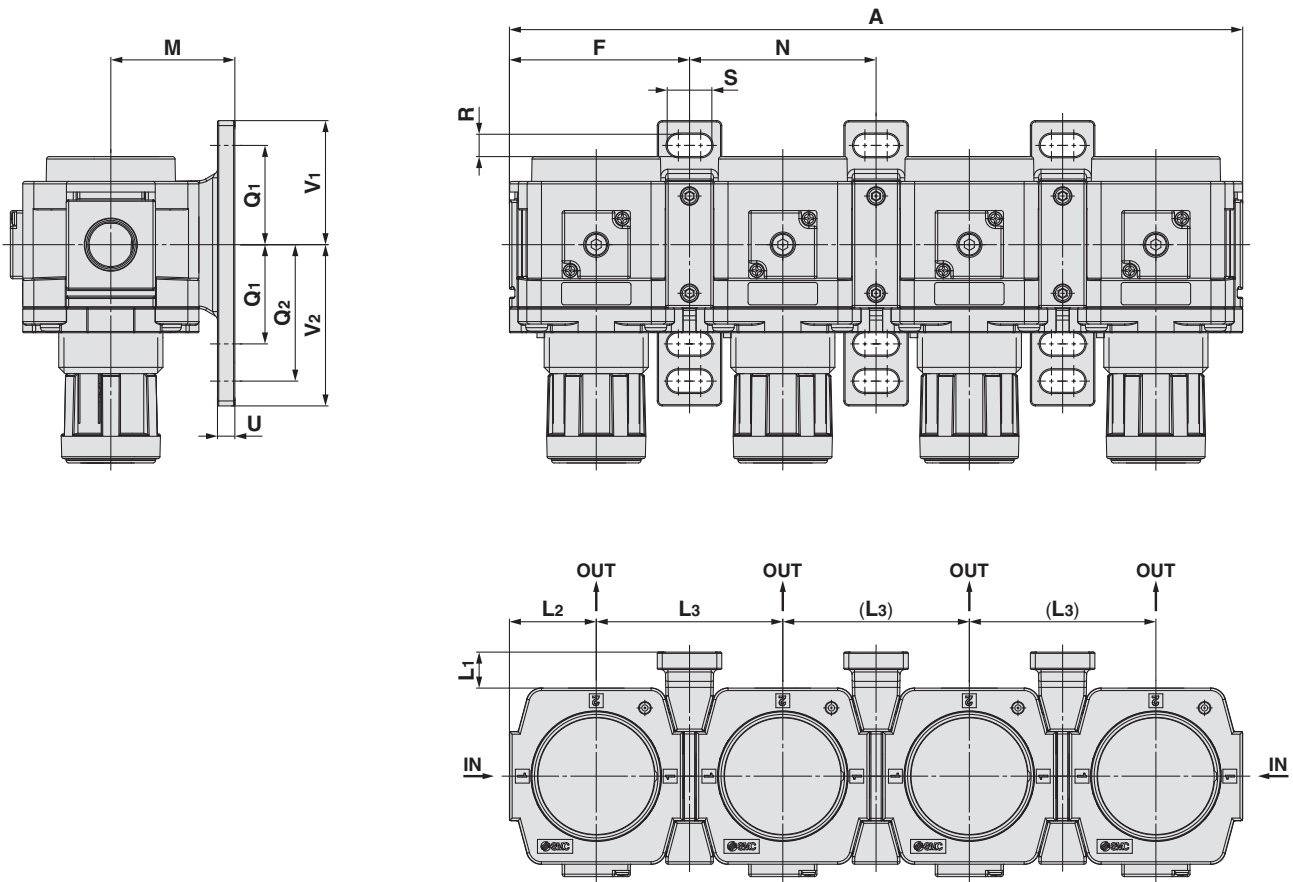

Model	Standard specifications													
	Bracket mount													
	A	F	L1	L2	L3	M	N	Q1	Q2	R	S	U	V1	V2
Size 20	169.6	41.6	9	21.6	43.2	30	43.2	24	33	5.5	11.5	3.5	29	38
Size 30	224.6	55.1	14.5	28.6	57.2	41	57.2	35	—	7	14	6	42.5	42.5
Size 40	295.6	72.6	14.5	37.6	75.2	50	75.2	40	55	9	18	7	50	65

AR20M(K)-D to AR40M(K)-D Series Modular Connection Examples

Products do not come assembled. They should be ordered separately and assembled by the customer.

For modular connection units (shipped assembled), the simple specials system can be used. For details, refer to page 2.

Combination example ①

Common Supply Regulator AR30M-0302E-D — 4 pcs.
Spacer with Bracket Y300T-D — 3 pcs.

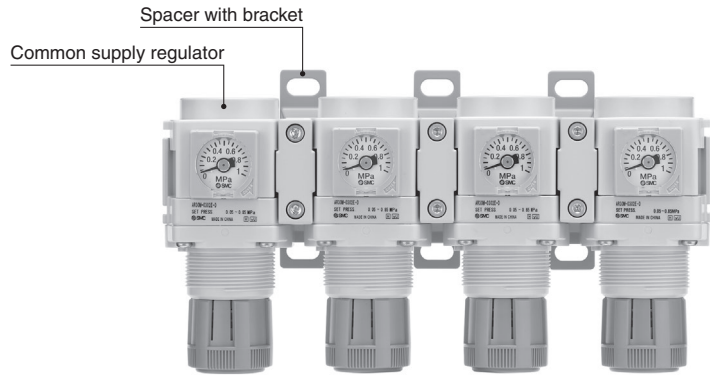

Combination example ②

Pressure Relief 3-Port Valve VHS30-03-D — 1 pc.
Spacer with Bracket Y300T-D — 4 pcs.
Air Filter AF30-03-D — 1 pc.
Common Supply Regulator with Backflow Function AR30MK-0302E-D — 2 pcs.
Regulator with Backflow Function AR30K-03E-D — 1 pc.

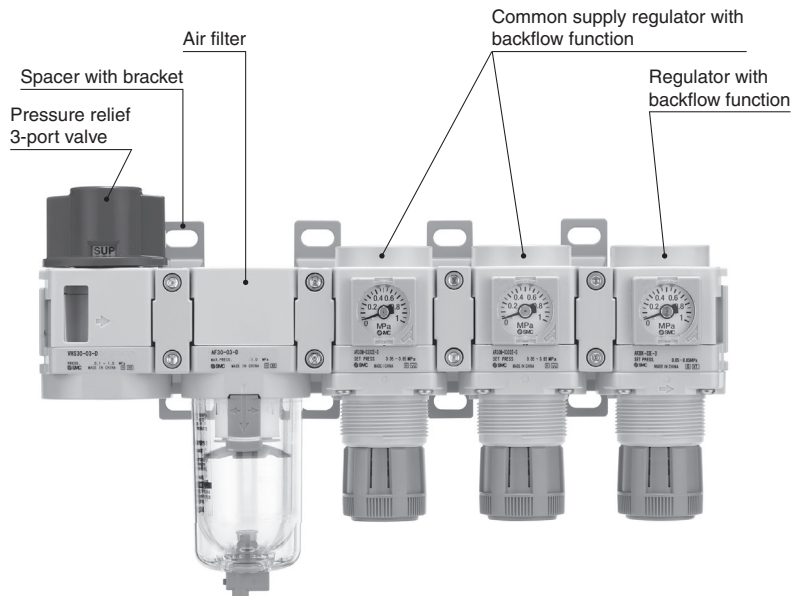

Combination example ③

- | | |
|---------------------------------------|--------|
| Air Filter AF30-03-D | 1 pc. |
| Spacer with Bracket Y300T-D | 4 pcs. |
| Common Supply Regulator AR30M-0302E-D | 1 pc. |
| Regulator AR30-03E-D | 1 pc. |
| Mist Separator AM30-03-D | 1 pc. |
| Micro Mist Separator AMD30-03-D | 1 pc. |

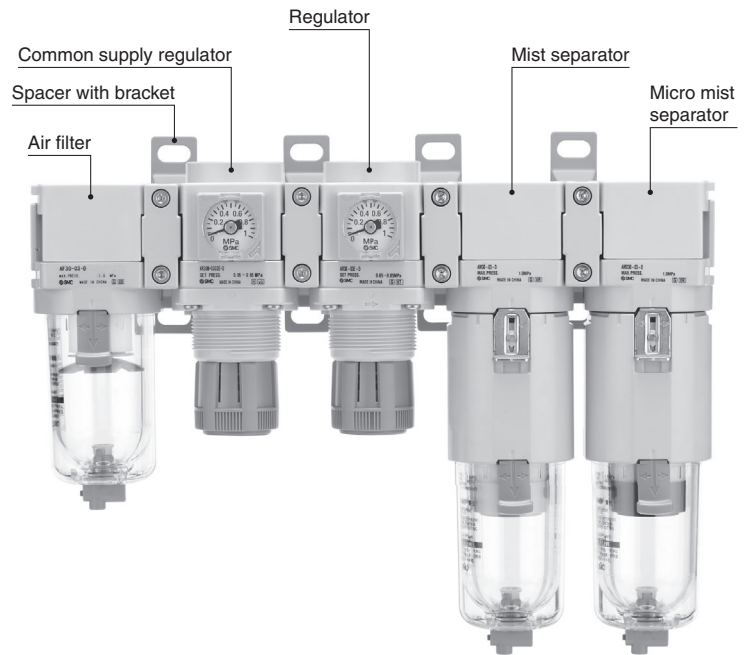

Combination example ④

- | | |
|---------------------------------------|--------|
| Common Supply Regulator AR30M-0302E-D | 4 pcs. |
| Spacer with Bracket Y300T-D | 4 pcs. |
| T-spacer Y310-03-D | 1 pc. |

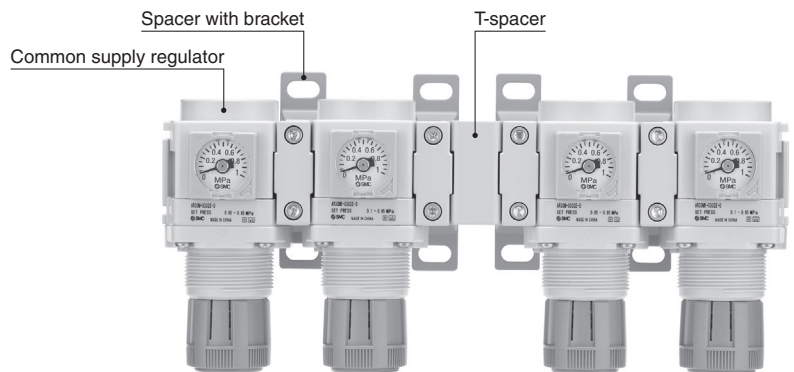

AR20M(K)-D to AR40M(K)-D Series Spacer / Spacer with Bracket

Spacer / Spacer with Bracket

Y 300 □ - D

① ②

				①		
				Body size [Applicable size]		
	Symbol	Description	200 [AR20M(K)]	300 [AR30M(K)]	400 [AR40M(K)]	
②	Bracket	—	Spacer	●	●	●
		T	Spacer with bracket	●	●	●

Spacer
(Y□-D)



Spacer with bracket
(Y□T-D)



Standard Specifications

Fluid	Air
Ambient and fluid temperatures	-5 to 60 °C (No freezing)
Proof pressure	1.5 MPa
Max. operating pressure	1.0 MPa

Replacement Parts

Description	Material	Part number		
		Y200-D Y200T-D	Y300-D Y300T-D	Y400-D Y400T-D
Seal	HNBR	Y220P-050S	Y320P-050S	Y420P-050S

Dimensions

Spacer

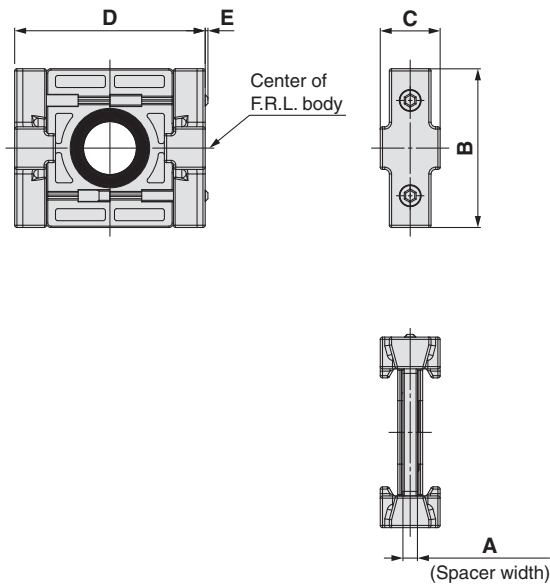

Spacer with bracket

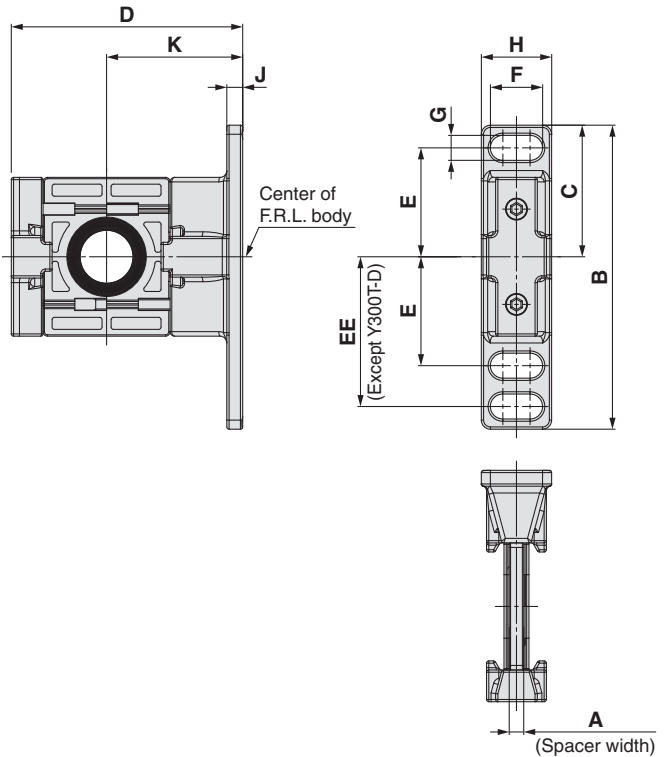

Part no.	A	B	C	D	E	Applicable size
Y200-D	3.2	35	13.2	42	0.6	AR20M(K)
Y300-D	4.2	43	16.2	53	—	AR30M(K)
Y400-D	5.2	51	19.2	71	—	AR40M(K)

Part no.	A	B	C	D	E	EE	F	G	H	J	K	Applicable size
Y200T-D	3.2	67	29	51	24	33	11.5	5.5	15.5	3.5	30	AR20M(K)
Y300T-D	4.2	85	42.5	67.5	35	—	14	7	20	6	41	AR30M(K)
Y400T-D	5.2	115	50	85.5	40	55	18	9	26	7	50	AR40M(K)



AR□M(K)-D Series Specific Product Precautions 1

Be sure to read this before handling the products. Refer to the back cover for safety instructions. For F.R.L. units precautions, refer to the “Handling Precautions for SMC Products” and the “Operation Manual” on the SMC website: <https://www.smc.eu>

Design / Selection

Warning

1. Residual pressure disposal (outlet pressure removal) is not possible for the AR 20 M-D to AR 40 M-D even though the inlet pressure is exhausted.

When the residual pressure disposal is performed, use the regulator with a backflow function (AR20MK-D to AR40MK-D).

Caution

1. When multiple regulators are connected together, supply an adequate amount of air as shown below.

When supply air is inadequate, the flow characteristics show (refer to page 6) will not be obtained.

Ex. 1) Supply from both sides

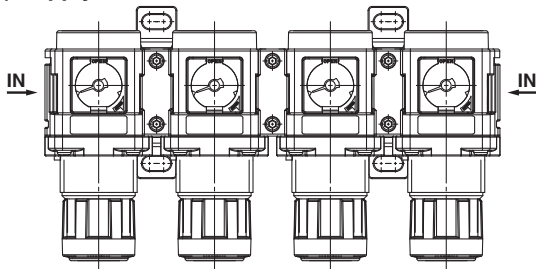

Ex. 2) Supply from both sides and in the middle

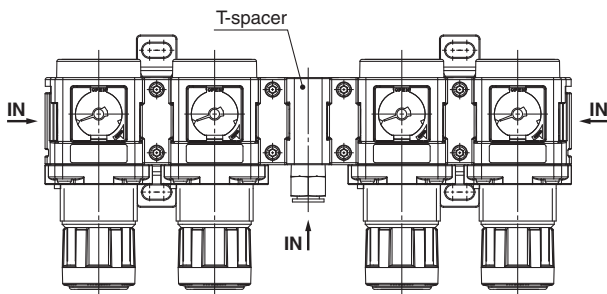

2. The common supply regulator with the backflow function cannot be installed between a solenoid valve and actuator.

For that application, please use the AR□K-D series.

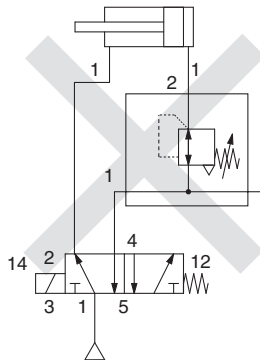

3. If a common supply regulator is installed at the outlet of a regulator, pulsations may be generated.

In this case, change the piping and pressure conditions to eliminate the pulsations.

Mounting / Adjustment

Warning

1. Set the regulator while verifying the displayed values of the inlet and outlet pressure gauges.

Turning the regulator knob excessively can cause damage to the internal parts.

2. Do not use tools on the pressure regulator knob as this may cause damage. It must be operated manually.

Caution

1. Be sure to unlock the knob before adjusting the pressure and lock it after setting the pressure.

Failure to follow this procedure can cause damage to the knob and the outlet pressure may fluctuate.

- Pull the pressure regulator knob to unlock. (You can visually verify this with the “orange mark” that appears in the gap.)
- Push the pressure regulator knob to lock. When the knob is not easily locked, turn it left and right a little and then push it (when the knob is locked, the “orange mark”, i.e., the gap will disappear).

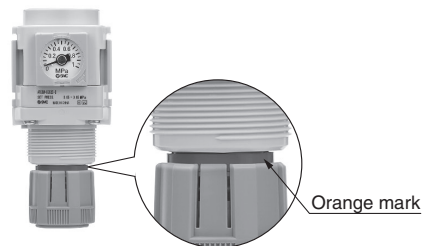



AR□M(K)-D Series Specific Product Precautions 2

Be sure to read this before handling the products. Refer to the back cover for safety instructions. For F.R.L. units precautions, refer to the “Handling Precautions for SMC Products” and the “Operation Manual” on the SMC website: <https://www.smc.eu>

Piping

Warning

1. Tighten the 2 holding screws on the spacer with bracket or spacer evenly.

Tighten them to the recommended tightening torque.
Insufficient tightening torque may result in loosening or sealing failure. Excessive tightening torque may damage the thread, etc.

Recommended Torque

Unit: N·m

Applicable model	AR20M(K)-D	AR30M(K)-D	AR40M(K)-D
Spacer with bracket part number	Y200T-D	Y300T-D	Y400T-D
Spacer part number	Y200-D	Y300-D	Y400-D
Torque	0.36 ±0.036	1.2 ±0.05	1.2 ±0.05

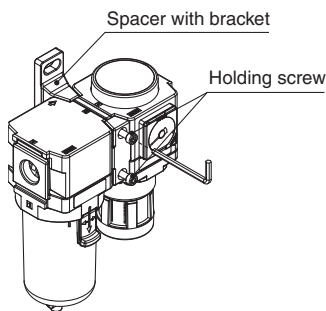

2. Place the spacer with bracket (or spacers) so that excessive moment is not applied to the spacer with bracket (or spacers) due to the weight of the product or the external force applied at the time of piping.

If the moment including the own weight of the external piping exceeds the maximum moment shown in the table below, support the external piping separately.

Piping materials without flexibility, such as steel tube piping, are prone to being affected by excess moment loads or vibrations from the piping side. Use flexible tubing in between to avoid such effects.

Unit: N·m

Applicable model	AR20M(K)-D	AR30M(K)-D	AR40M(K)-D
Max. moment (M)	14.5	16	19.5

Max. moment (M) = Length (L) x Load (F)

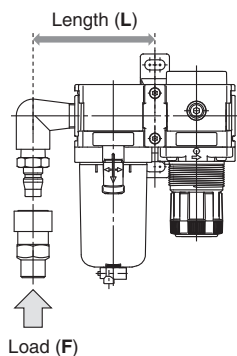

Piping

Warning

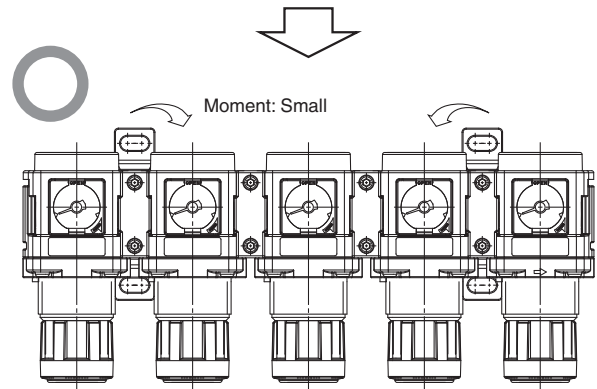
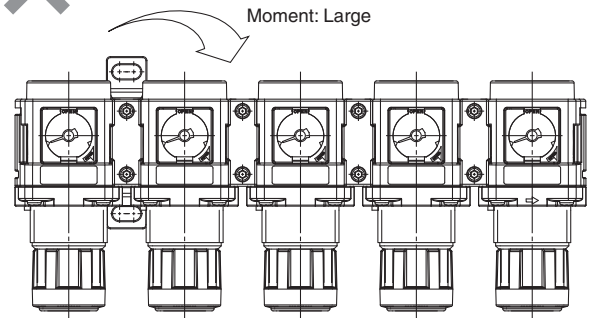

3. Connect piping/fittings using the recommended torque while holding the female thread side tightly.

Insufficient tightening torque can result in loose piping or sealing failure. Over tightening may break the thread. If the female side is not held while tightening, excessive force will be applied to the bracket directly, resulting in breakage.

Recommended Torque

Unit: N·m



Connection thread	1/8	1/4	3/8	1/2
Torque	7 to 9	12 to 14	22 to 24	28 to 30

4. To screw the pressure gauge and piping materials into the pressure gauge port on the product, tighten to the recommended torque (3 to 5 N·m) while securely holding the AR□M(K)-D in place.

5. When mounting a One-touch fitting, refer to the Fittings and Tubing Precautions.

Safety Instructions

These safety instructions are intended to prevent hazardous situations and/or equipment damage. These instructions indicate the level of potential hazard with the labels of “**Caution**,” “**Warning**” or “**Danger**.” They are all important notes for safety and must be followed in addition to International Standards (ISO/IEC)¹⁾, and other safety regulations.

-  **Caution:** **Caution** indicates a hazard with a low level of risk which, if not avoided, could result in minor or moderate injury.
-  **Warning:** **Warning** indicates a hazard with a medium level of risk which, if not avoided, could result in death or serious injury.
-  **Danger:** **Danger** indicates a hazard with a high level of risk which, if not avoided, will result in death or serious injury.

- 1) ISO 4414: Pneumatic fluid power – General rules relating to systems.
ISO 4413: Hydraulic fluid power – General rules relating to systems.
IEC 60204-1: Safety of machinery – Electrical equipment of machines.
(Part 1: General requirements)
- ISO 10218-1: Manipulating industrial robots - Safety.
etc.

Warning

1. The compatibility of the product is the responsibility of the person who designs the equipment or decides its specifications.

Since the product specified here is used under various operating conditions, its compatibility with specific equipment must be decided by the person who designs the equipment or decides its specifications based on necessary analysis and test results. The expected performance and safety assurance of the equipment will be the responsibility of the person who has determined its compatibility with the product. This person should also continuously review all specifications of the product referring to its latest catalogue information, with a view to giving due consideration to any possibility of equipment failure when configuring the equipment.

2. Only personnel with appropriate training should operate machinery and equipment.

The product specified here may become unsafe if handled incorrectly. The assembly, operation and maintenance of machines or equipment including our products must be performed by an operator who is appropriately trained and experienced.

3. Do not service or attempt to remove product and machinery/equipment until safety is confirmed.

1. The inspection and maintenance of machinery/equipment should only be performed after measures to prevent falling or runaway of the driven objects have been confirmed.
2. When the product is to be removed, confirm that the safety measures as mentioned above are implemented and the power from any appropriate source is cut, and read and understand the specific product precautions of all relevant products carefully.
3. Before machinery/equipment is restarted, take measures to prevent unexpected operation and malfunction.

4. Contact SMC beforehand and take special consideration of safety measures if the product is to be used in any of the following conditions.

1. Conditions and environments outside of the given specifications, or use outdoors or in a place exposed to direct sunlight.
2. Installation on equipment in conjunction with atomic energy, railways, air navigation, space, shipping, vehicles, military, medical treatment, combustion and recreation, or equipment in contact with food and beverages, emergency stop circuits, clutch and brake circuits in press applications, safety equipment or other applications unsuitable for the standard specifications described in the product catalogue.
3. An application which could have negative effects on people, property, or animals requiring special safety analysis.
4. Use in an interlock circuit, which requires the provision of double interlock for possible failure by using a mechanical protective function, and periodical checks to confirm proper operation.

Caution

1. The product is provided for use in manufacturing industries.

The product herein described is basically provided for peaceful use in manufacturing industries.

If considering using the product in other industries, consult SMC beforehand and exchange specifications or a contract if necessary. If anything is unclear, contact your nearest sales branch.

Limited warranty and Disclaimer/Compliance Requirements

The product used is subject to the following “Limited warranty and Disclaimer” and “Compliance Requirements”. Read and accept them before using the product.

Limited warranty and Disclaimer

1. The warranty period of the product is 1 year in service or 1.5 years after the product is delivered, whichever is first.²⁾ Also, the product may have specified durability, running distance or replacement parts. Please consult your nearest sales branch.
2. For any failure or damage reported within the warranty period which is clearly our responsibility, a replacement product or necessary parts will be provided. This limited warranty applies only to our product independently, and not to any other damage incurred due to the failure of the product.
3. Prior to using SMC products, please read and understand the warranty terms and disclaimers noted in the specified catalogue for the particular products.
- 2) Vacuum pads are excluded from this 1 year warranty.
A vacuum pad is a consumable part, so it is warranted for a year after it is delivered. Also, even within the warranty period, the wear of a product due to the use of the vacuum pad or failure due to the deterioration of rubber material are not covered by the limited warranty.

Compliance Requirements

1. The use of SMC products with production equipment for the manufacture of weapons of mass destruction (WMD) or any other weapon is strictly prohibited.
2. The exports of SMC products or technology from one country to another are governed by the relevant security laws and regulations of the countries involved in the transaction. Prior to the shipment of a SMC product to another country, assure that all local rules governing that export are known and followed.

Caution

SMC products are not intended for use as instruments for legal metrology.

Measurement instruments that SMC manufactures or sells have not been qualified by type approval tests relevant to the metrology (measurement) laws of each country. Therefore, SMC products cannot be used for business or certification ordained by the metrology (measurement) laws of each country.

Safety Instructions

Be sure to read “Handling Precautions for SMC Products” (M-E03-3) before using.

SMC Corporation (Europe)

Austria	+43 (0)2262622800	www.smc.at	office@smc.at
Belgium	+32 (0)33551464	www.smc.be	info@smc.be
Bulgaria	+359 (0)2807670	www.smc.bg	office@smc.bg
Croatia	+385 (0)13707288	www.smc.hr	office@smc.hr
Czech Republic	+420 541424611	www.smc.cz	office@smc.cz
Denmark	+45 70252900	www.smc.dk.com	smc@smcdk.com
Estonia	+372 6510370	www.smc.pneumatics.ee	smc@info@smcee.ee
Finland	+358 207513513	www.smc.fi	smc@smc.fi
France	+33 (0)164761000	www.smc-france.fr	info@smc-france.fr
Germany	+49 (0)61034020	www.smc.de	info@smc.de
Greece	+30 210 2717265	www.smchellas.gr	sales@smchellas.gr
Hungary	+36 23513000	www.smc.hu	office@smc.hu
Ireland	+353 (0)14039000	www.smcautomation.ie	sales@smcautomation.ie
Italy	+39 03990691	www.smcitalia.it	mailbox@smcitalia.it
Latvia	+371 67817700	www.smc.lv	info@smc.lv

Lithuania	+370 5 2308118	www.smclt.lt	info@smclt.lt
Netherlands	+31 (0)205318888	www.smc.nl	info@smc.nl
Norway	+47 67129020	www.smc-norge.no	post@smc-norge.no
Poland	+48 222119600	www.smc.pl	office@smc.pl
Portugal	+351 214724500	www.smc.eu	apoioclientept@smc.smces.es
Romania	+40 213205111	www.smcromania.ro	smcromania@smcromania.ro
Russia	+7 8127185445	www.smc-pneumatik.ru	info@smc-pneumatik.ru
Slovakia	+421 (0)413213212	www.smc.sk	office@smc.sk
Slovenia	+386 (0)73885412	www.smc.si	office@smc.si
Spain	+34 945184100	www.smc.eu	post@smc.smces.es
Sweden	+46 (0)86031240	www.smc.nu	smc@smc.nu
Switzerland	+41 (0)523963131	www.smc.ch	info@smc.ch
Turkey	+90 212 489 0 440	www.smc.pnomatik.com.tr	info@smc.pnomatik.com.tr
UK	+44 (0)845 121 5122	www.smc.uk	sales@smc.uk